

HOW TO SELECT HYDRAULIC BRAKES AND BRAKE PARTS

THE SINGLE-SERVO / DUO-SERVO DIFFERENCE:

1. **SINGLE-SERVO:** Single plunger coming from the wheel cylinder, most commonly used with Surge Brake applications.
2. **DUO-SERVO:** Two plungers coming from the wheel cylinder, stops vehicle in both forward and reverse motion.



Single-Servo Cylinder



Duo-servo Cylinder

SELECTING HYDRAULIC BRAKE PARTS:

1. Determine the size of your brake. a. Measure the diameter of the mounted brake shoe. b. Measure the width of the lining.
2. Determine the manufacturer of your brake. a. Is the manufacturer's name on the backing plate b. Compare to complete Brake Assembly or to exploded drawings in this catalog.
3. Select each part you need. The exploded drawings of each brake are to assist you in selecting the parts you need. Though all parts may be shown, we carry replacement parts only for those that are numbered. Parts labeled "Parts Only" indicate that complete brake assemblies are not available.

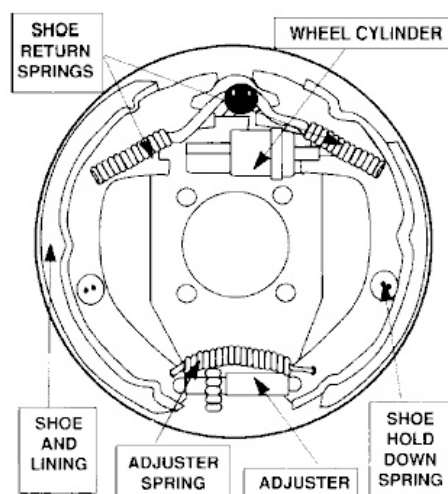

USING THE HYDRAULIC BRAKE CHART:

1. Find the picture that matches the assembly or the part you need.
2. The part and reference numbers are just below the picture of your assembly or part. Part numbers are placed beside the photo of individual replacement parts. Use the part number to order what you need.
3. Double check your part against its listing in the pages which show the exploded drawings.
4. Call or fax your order to the location nearest you.

REASONS WHY BRAKE HARDWARE SHOULD BE REPLACED:

- A. Worn, weak return springs will cause the brake linings to drag against the drum and cause premature brake failure.
- B. Hold down springs will lose their tension and allow the brake shoes to wobble or ride Duo-Servo Cylinder up against the face of the brake drum, causing premature lining failure.
- C. A frozen adjusting screw will not allow shoes to be adjusted properly.
- D. Rubber dust plugs will crack with age and allow dirt to contaminate linings. (not shown or illustrated)
- E. A stretched self-adjusting cable or worn lever prevents the self-adjusting lever from properly aligning the shoes. (Not shown or illustrated)

